

NUOVO PALERMO

KARTA TECHNICZNA / TECHNICAL INFORMATION

FR-PLX

Płytko do elektrozaczeplu – krótka dla TGE65-R, TGE65-S

Short strike plate for TGE65-R, TGE65-S

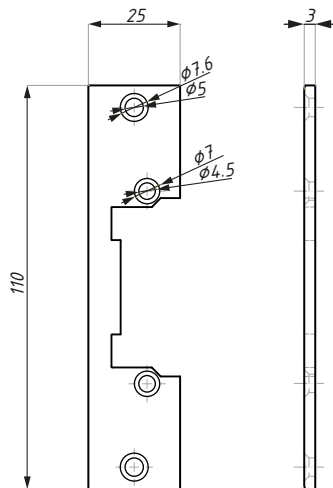

Kod / Code

FR-PLX SSS

Materiał / Material

stal nierdzewna / stainless steel

UWAGA: Informacje na temat frezowania znajdują się w instrukcji oraz na www.cdapolska.pl
ATTENTION: For the milling of the profiles please refer to the instruction on the web page www.cdapolska.pl

CDA Polska Sp. z o.o. Sp. k.

Ul. Robotnicza 60, 53-608 Wrocław



 www.cdapolska.pl

 www.oszkle.pl

 www.sklep.cdapolska.pl



 biuro@cdapolska.pl

 Wrocław: 71 797 80 28

 Warszawa: 22 675 05 89

 Gdynia: 58 719 28 78