

# NUOVO PALERMO

KARTA TECHNICZNA / TECHNICAL INFORMATION

## FRN-PCL

Płytko do zamków serii ERICE LINE  
Strike plate for Erice Line locks

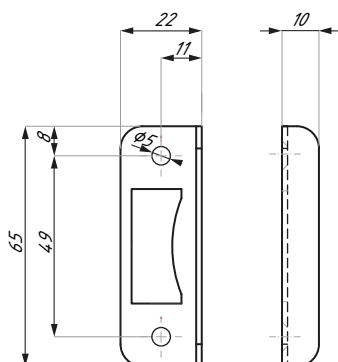

### Kod / Code

FRN-PCL SSS

### Materiał / Material

stal nierdzewna / stainless steel

UWAGA: Informacje na temat frezowania znajdują się w instrukcji oraz na [www.cdapolska.pl](http://www.cdapolska.pl)  
ATTENTION: For the milling of the profiles please refer to the instruction on the web page [www.cdapolska.pl](http://www.cdapolska.pl)

CDA Polska Sp. z o.o. Sp. k.

Ul. Robotnicza 60, 53-608 Wrocław



 [www.cdapolska.pl](http://www.cdapolska.pl)

 [www.oszkle.pl](http://www.oszkle.pl)

 [www.sklep.cdapolska.pl](http://www.sklep.cdapolska.pl)



 [biuro@cdapolska.pl](mailto:biuro@cdapolska.pl)

 Wrocław: 71 797 80 28

 Warszawa: 22 675 05 89

 Gdynia: 58 719 28 78