



ERICE LINE / LINEA NERA

KARTA TECHNICZNA / TECHNICAL INFORMATION

TGCR312

Zawias z płytką montażową
Hinge with fixing plate

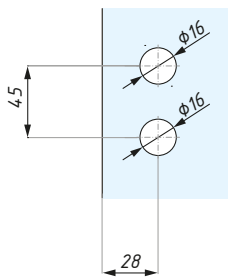

Przygotowanie szkła
Glass preparation

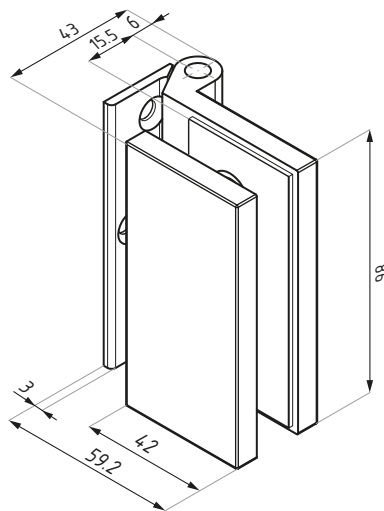

Kod / Code	Wykończenie / Finish
TGCR312 NABL	anoda czarna / black anodised
materiał: aluminium	materiał: aluminium
grubość szkła (mm): 8; 10; 12	glass thickness (mm): 8; 10; 12
max. waga szkła dla pary zawiasów (kg): 50	max. glass weight per pair hinges (kg): 50
max. szer. szkła (mm): 950	max. door width (mm): 950
zalecana siła dokręcania śrub (Nm): M6: 15	recommended torque force for screws (Nm): M6: 15

CDA Polska Sp. z o.o. Sp. k.

Ul. Robotnicza 60, 53-608 Wrocław



 www.cdapolska.pl

 www.oszkle.pl

 www.sklep.cdapolska.pl



 biuro@cdapolska.pl

 Wrocław: 71 797 80 28

 Warszawa: 22 675 05 89

 Gdynia: 58 719 28 78