



ERICE LINE

KARTA TECHNICZNA / TECHNICAL INFORMATION

TGS35S-E (R)

Przeciwkasetę z elektrozaczepekem
Strike patch with electric strike

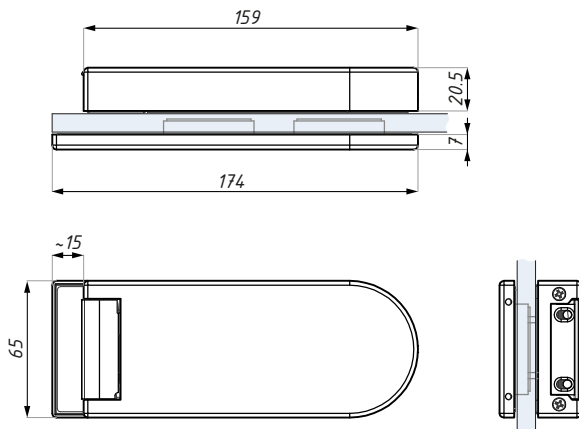

Kod / Code	Elektrozaczepek Electric strike	Wykończenie Finish
TGS35S-E SSS	standardowy / fail secure	satyna / satin
TGS35S-ER SSS	rewersyjny / fail safe	satyna / satin

materiał: stal nierdzewna materiał: stainless steel
grubość szkła (mm): 8; 10; 12 glass thickness (mm): 8; 10; 12

CDA Polska Sp. z o.o. Sp. k.

Ul. Robotnicza 60, 53-608 Wrocław



 www.cdapolska.pl

 www.oszkle.pl

 www.sklep.cdapolska.pl



 biuro@cdapolska.pl

 Wrocław: 71 797 80 28

 Warszawa: 22 675 05 89

 Gdynia: 58 719 28 78